

Flea[®] 3



ULTRA-COMPACT + VERSATILE + COST-EFFECTIVE

- Choice of 4 Sony progressive scan CCD's, mono or color
- FireWire-b 800 Mbit/s
- Ultra-compact 29 x 29 x 30 mm metal case, 58 grams
- Complies with IIDC 1.32

The fully redesigned, next generation Flea3 camera series builds on the success of the ultra-compact Flea2 by adding new Sony image sensors to the line-up. The Flea3 offers a host of new features, including enhanced opto-isolated GPIO; an on-camera frame buffer; non-volatile user data storage; new trigger modes; and improved imaging performance.



FireWire Models

FL3-FW-03S1C/M-C	0.3MP	Sony ICX618 CCD, 1/4", 5.6µm, Global Shutter	648x488 at 120 fps
FL3-FW-03S3C/M-C	0.3MP	Sony ICX414 CCD, 1/2", 9.9µm, Global Shutter	648x488 at 76 fps
FL3-FW-14S3C/M-C	1.4MP	Sony ICX267 CCD, 1/2", 4.65µm, Global Shutter	1384x1032 at 16 fps
FL3-FW-20S4C/M-C	2.0MP	Sony ICX274 CCD, 1/1.8", 4.4µm, Global Shutter	1624x1224 at 15 fps

Analog-to-Digital Converter	Analog Devices 12-bit ADC
Video Data Output	8, 12, 16 and 24-bit digital data
Image Data Formats	Y8, Y16, Mono8, Mono12, Mono16 (all models) RGB, YUV411, YUV422, Raw8, Raw12, Raw16 (color models)
Color Processing	On-camera in YUV or RGB format, or on-PC in Raw format
Digital Interface	IEEE 1394b 800 Mbit/s interface with screw locks for camera control, data, and power
Transfer Rates	100, 200, 400, 800 Mbit/s
Partial Image Modes	pixel binning and region of interest modes via Format 7
White Balance	automatic / manual modes, programmable via software
General Purpose I/O Ports	8-pin Hirose HR25 GPIO connector opto-isolated pins for trigger, pwm and strobe, bi-directional pins for trigger, strobe, pwm or serial port
Gain Control	automatic / manual / one-push gain modes, programmable via software, 0dB to 24dB in 0.046dB increments
Shutter Speed	automatic / manual / one-push modes, programmable via software, 0.02ms to greater than 10s (extended shutter mode)
Gamma/LUT	0.50 to 4.00 / programmable lookup table
Synchronization	via external trigger, software trigger (on same bus only), or free-running
External Trigger Modes	DCAM v1.32 Trigger Modes 0, 1, 3, 4, 5, 14 (overlapped trigger), and 15 (multi-shot trigger)
Power Consumption	power via Vext GPIO pin or 9-pin 1394b interface: 8 to 30 V, less than 2.5 W
Dimensions (L x W x H)	29mm x 29mm x 30mm (excluding lens holder, without optics)
Mass	58g (without optics)
Memory Storage	32 MB frame buffer; 1 MB non-volatile user data flash
Memory Channels	2 memory channels for user configuration sets
Camera Specification	IIDC 1394-based Digital Camera Specification v1.32, compatible with IEEE-1394b and IEEE-1394a interfaces
Lens Mount	C-mount
Emissions Compliance	CE, FCC-A, RoHS
Operating Temperature	0° to 45°C
Storage Temperature	-30° to 60°C
Warranty	2 year

Flea[®]3 Specifications

IEEE-1394b Benefits

The bilingual IEEE-1394b interface used by the Flea3 camera provides reliable, deterministic communication with guaranteed bandwidth and 800 Mb/s data rates. The Flea3 supports data transfer rates up to 800 Mb/s, and is backward compatible with 1394a, allowing it to work seamlessly with existing 1394a systems.

Ultra-compact 1394b Camera

At 29x29x30mm, the Flea3 fits into the small, tight spaces that are common in industrial imaging, making it an ideal camera for OEM applications. The 1394b connector with locking screw holes not only guarantee a reliable connection, but also reduce stress on internal electronics that can be caused by cable movement. The cable also carries both data and power, minimizing the need for additional cables or external power sources.

Triggering and GPIO

The Flea3 camera has an 8-pin GPIO connector located on the back. The opto-isolated pins allows the user to coordinate the camera with external devices such as light sources and GPS units. It can be programmed to accept external trigger signals that initiate the start of exposure, output variable strobe patterns, or send and receive serial data.

Industry Standard Mechanics

Every mechanical component of the Flea3 is designed to maximize usability, including the compact cast metal case, C-mount lens holder and ASA/ISO-compliant tripod mounting bracket, status LED and removable glass/IR filter system.

Dimensional Drawings (in mm)

CAD models available at www.ptgrey.com/support/downloads.

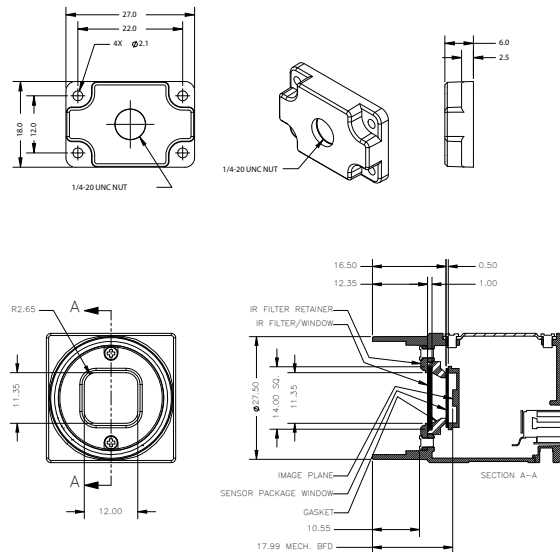
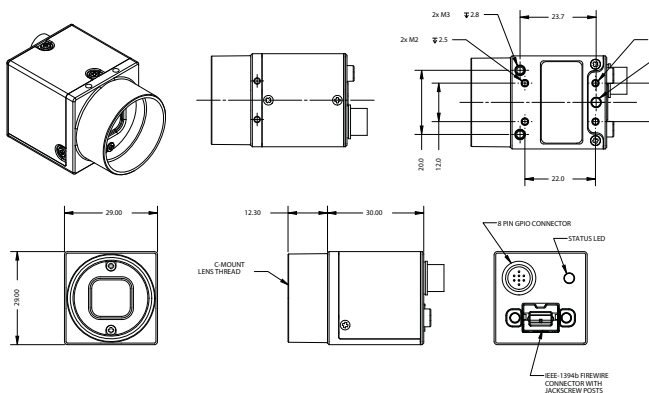

NOTE:
 1. CAMERA USES IR FILTER WITH COLOUR SENSORS, AND A CLEAR WINDOW WITH MONOCHROME SENSORS.
 2. THE REFRACTIVE INDEX OF THE IR FILTER/WINDOW, AND THE SENSOR PACKAGE WINDOW IS 1.5.
 3. THIS IS A C-MOUNT CAMERA. C-MOUNT LENSES CAN NOT BE USED WITH THIS CAMERA.
 4. THE MECHANICAL BACK FLANGE DISTANCE (MECH. BFD) IS GREATER THAN THE NOMINAL 17.526MM C-MOUNT BFD DUE TO THE FILTER AND WINDOW(S) BETWEEN THE LENS AND THE IMAGE PLANE.

Color Processing

The color Flea3 features on-camera color processing and auto white balance. Available outputs include YUV411, YUV422, RGB, Y8 and Y16. If a reduction in the bus bandwidth is required, users can access the raw Bayer pattern.

Automatic Synchronization

Multiple Flea3 cameras networked on the same IEEE-1394 bus are automatically synchronized to within 125µs (maximum deviation) of each other, and can synchronize across buses using Point Grey MultiSync™ software.

Software

The FlyCapture® SDK is included with all imaging products. The SDK is compatible with Microsoft Windows and Linux Ubuntu. It includes device drivers, software Application Programming Interface (API), demo programs and C/C++ example source code. It also includes the FirePROT™ driver, which provides enhanced debugging and diagnostics, and allows 1394b devices to run at 800Mb/s.

Development Accessory Kit

- 4.5 meter, 9-pin to 9-pin, IEEE-1394b cable with locking screws for secure connection
- 4.5 meter, 6-pin to 9-pin, IEEE-1394a to 1394b cable for secure connection
- IEEE-1394b OHCI PCI Host Adapter 3-port 800Mb/s card
- 1 meter GPIO wiring harness with HR25 8-pin male connector for easy triggering
- FlyCapture® SDK (C/C++ API and device drivers) CD